

7. PARTS LIST

7.1 LIFT ASSEMBLY

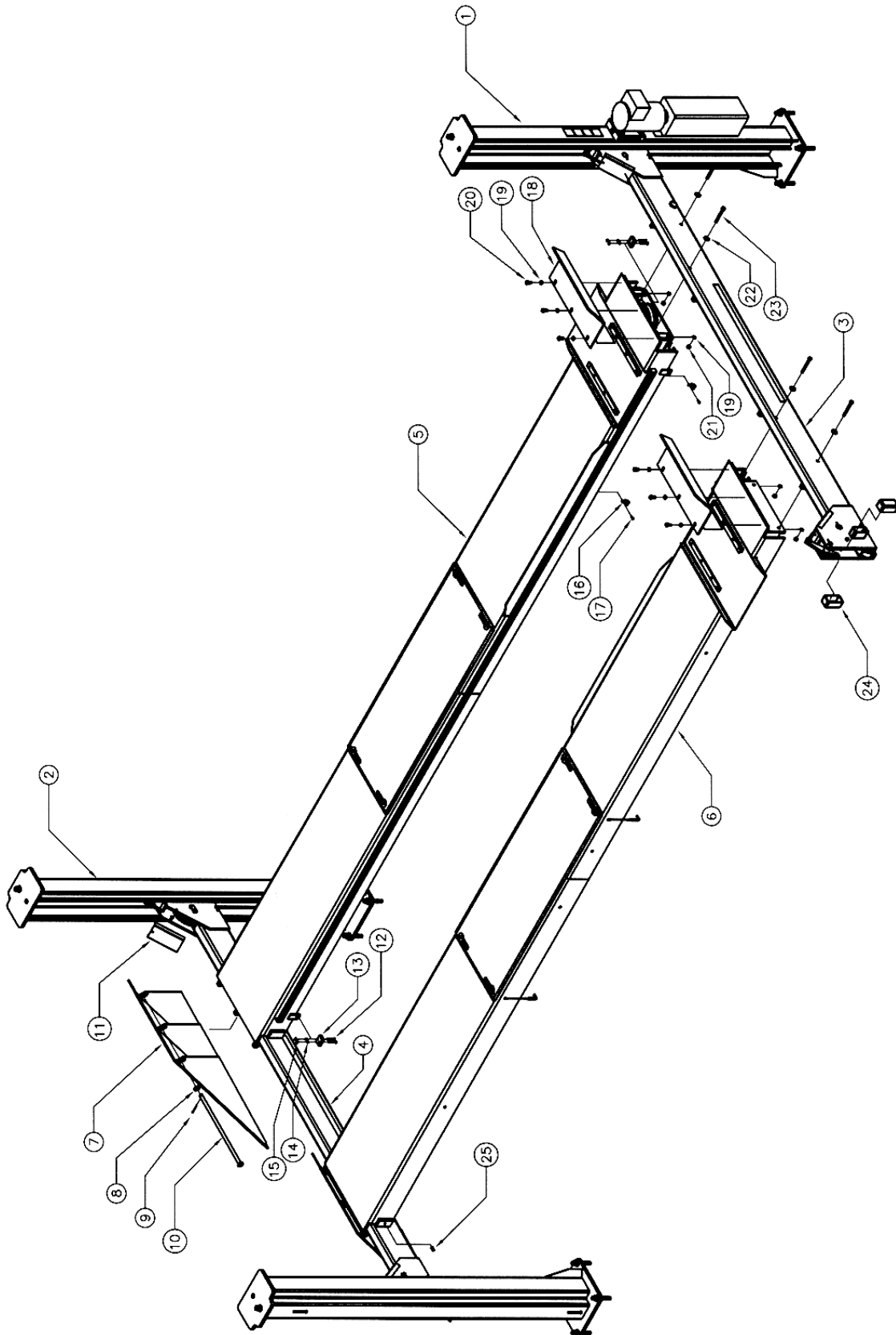

7.2 PARTS LIST - LIFT ASSEMBLY

ITEM	QTY.	DESCRIPTION	PART #
1	1	TOWER WELDMENT - POWER POST	4-0636
2	3	TOWER WELDMENT	4-0630
3	1	FRONT CROSSMEMBER WELDMENT	4-0627
4	1	REAR CROSSMEMBER WELDMENT	4-0626
5	1	DECK WELDMENT - L.S. (ALIGNMENT)	4-0629
	1	DECK WELDMENT - L.S. (SERVICE)	4-0916
6	1	DECK WELDMENT - R.S. (ALIGNMENT)	4-0628
	1	DECK WELDMENT - R.S. (SERVICE)	4-0917
7	2	APPROACH RAMP WELDMENT	3-0680
8	2	FLAT WASHER, 3/4"ID	6-0738
9	2	COTTER PIN, 1/8" x 2"LG	6-0115
10	2	APPROACH RAMP PIN	2-1381
11	4	SHEAVE COVER	2-1379
12	4	HEX HD BOLT, 1/4"-20UNC x 2"LG	6-0177
13	2	MANIFOLD	1-1057
14	4	LOCKWASHER, 1/4"ID	6-0056
15	4	HEX NUT, 1/4"-20UNC	6-0032
16	2	HOSE CLAMP, 3/4"	6-1683
17	2	SELF THREADING SCREW, #10 x 3/4"LG	6-0297
18	2	FRONT WHEELSTOP	2-0998
19	14	LOCKWASHER, 1/2"ID	6-0059
20	6	HEX HD BOLT, 1/2"-13UNC x 1"LG	6-0045
21	8	HEX NUT, 1/2"-13UNC	6-0035
22	8	FLAT WASHER, 1/2"ID	6-0063
23	8	HEX HD BOLT, 1/2" x 4 1/2"	6-1694
24	8	GLIDE BEARING	2-0772
25	4	SET SCREW, 1/2"-13UNC x 1"LG	6-0726

7.3 TOWER ASSEMBLY

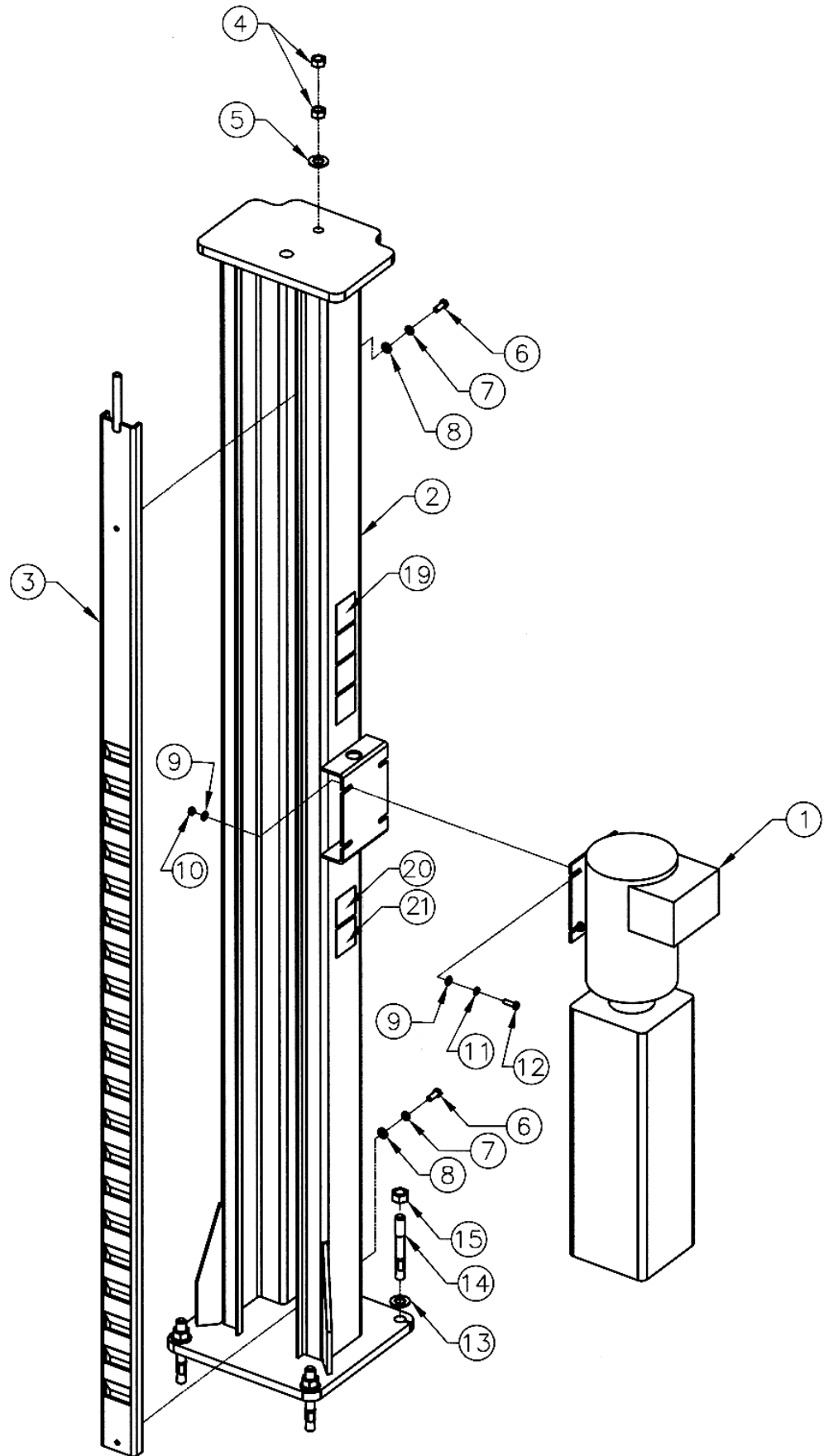

7.4 PARTS LIST - TOWER ASSEMBLY

ITEM	QTY.	DESCRIPTION	PART #
1	1	POWER PACK, 230V/1PH	6-1695
	1	POWER PACK, 230V/3PH	6-2615
2	1	POWER POST WELDMENT	4-0636
3	1	SAFETY RACK WELDMENT	3-0581
4	2	HEX NUT, 5/8"-11UNC, GR8	6-0673
5	1	FLAT WASHER, 3/4" I.D.	6-0738
6	2	HEX HD. BOLT, 3/8"-16UNC X 1"LG., GR.8	6-0668
7	2	LOCK WASHER, 3/8" I.D.	6-0058
8	2	FLAT WASHER, 3/8" I.D.	6-0625
9	8	FLAT WASHER, 5/16" I.D.	6-0295
10	4	HEX NUT, 5/16"-18UNC, GR.8	6-0294
11	4	LOCK WASHER, 5/16" I.D.	6-0674
12	4	HEX HD BOLT, 5/16"-18UNC X 1"LG., GR.8	6-0293
13	4	FLAT WASHER, 3/4" I.D.	6-0738
14	4	WEDGE ANCHOR, 3/4"-10UNC X 5 1/2"LG.	6-1379
15	4	HEX NUT, 3/4"-10UNC	6-0737
19	1	"ATTENTION" DECAL	6-1637
20	1	SERIAL TAG	
21	1	DECAL SET, ALI/WL 200	6-0988

NOTE: Refer to section 7.1 for other Tower Weldment part numbers.

7.5 DECK ASSEMBLY (LEFT SIDE)

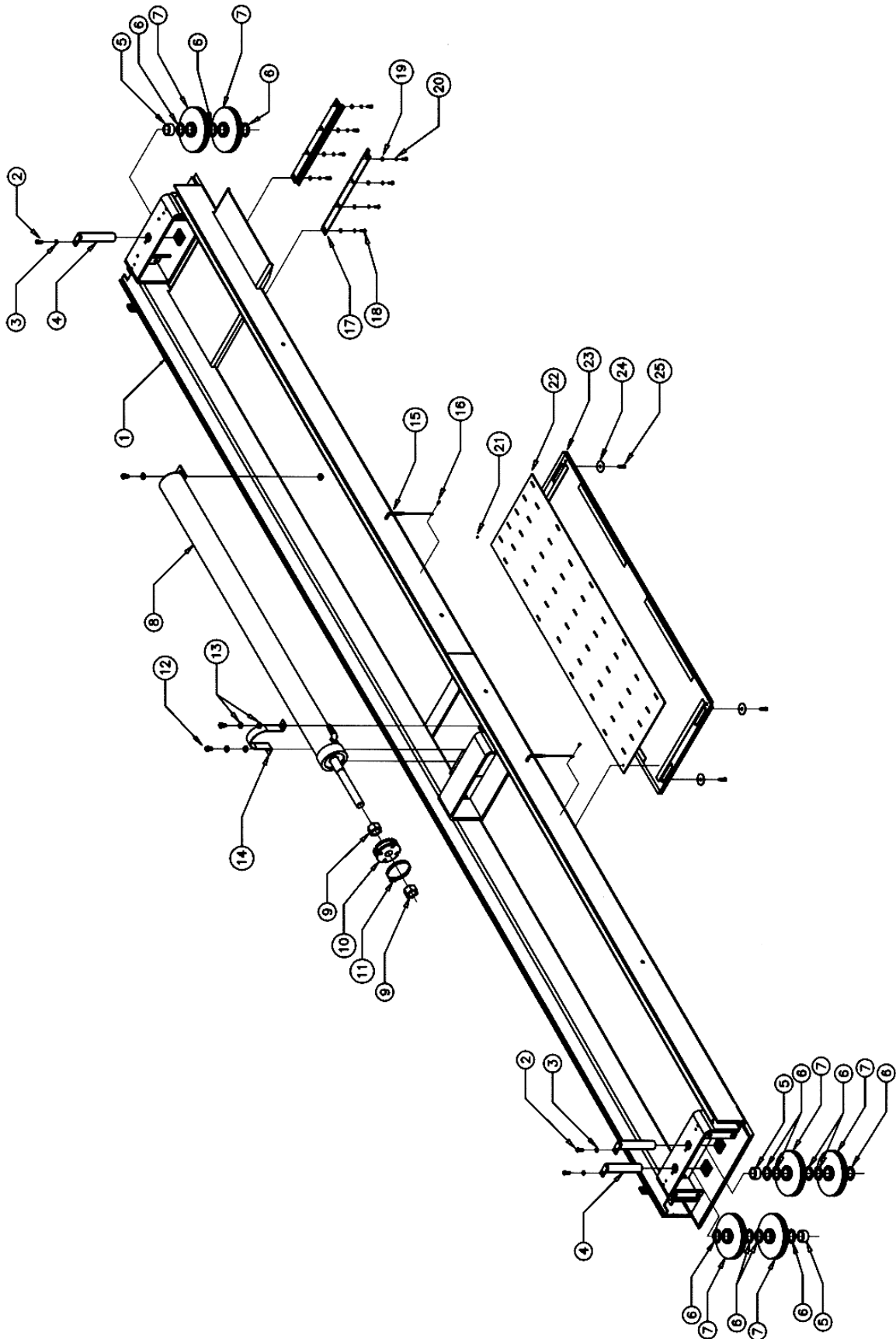

7.6 PARTS LIST - DECK ASSEMBLY (LEFT SIDE)

ITEM	QTY.	DESCRIPTION	PART #
1	1	DECK WELDMENT - L.S. (ALIGNMENT)	4-0629
	1	DECK WELDMENT - L.S. (SERVICE)	4-0916
2	3	HEX HD BOLT, 3/8"-16UNC x 1" LG	6-0668
3	3	LOCKWASHER, 3/8"	6-0058
4	3	DECK SHEAVE PIN WELDMENT	2-1355
5	3	SHEAVE SPACER, 1"	1-1697
6	12	NYLON THRUST WASHER	1-0757
7	6	SHEAVE ASSEMBLY	2-1377
8	1	CYLINDER ASSEMBLY - 4" BORE	3-0681
9	2	HEX NUT, 1 3/8"-12UNF	6-1644
10	1	CABLE FLANGE (18K 4POST)	2-1432
11	1	HOSE CLAMP, 4 1/2" DIA	6-0665
12	3	HEX HD BOLT, 1/2"DIA x 3/4" LG	6-0044
13	5	WASHER, 1/2"ID	6-0248
14	1	CYLINDER SLING	1-1747
15	2	LOCKING PIN ASSEMBLY	2-0637
16	2	SELF TAPPING SCREW, #10 x 1/2" LG	6-0505
17	2	RETAINING BAR	2-1391
18	8	HEX HD BOLT, 1/4"-20UNC x 3/4" LG	6-0128
19	8	WASHER, 1/4" ID	6-0060
20	8	LOCKWASHER, 1/4" ID	6-0056
21	1	1/4" BALL BEARING (1 PACKET)	6-0829
22	1	BEARING CAGE	3-0196
23	1	REAR SLIP PLATE (FULL FLOATING)	3-0197
24	4	FLAT WASHER, 2" OD x 13/32" ID	6-0426
25	4	SHOULDER BOLT, 3/8" x 5/8" LG	6-0069

NOTE: Refer to section 7.1 for Right Side Deck Weldment part numbers.

7.7 CROSSMEMBER ASSEMBLY

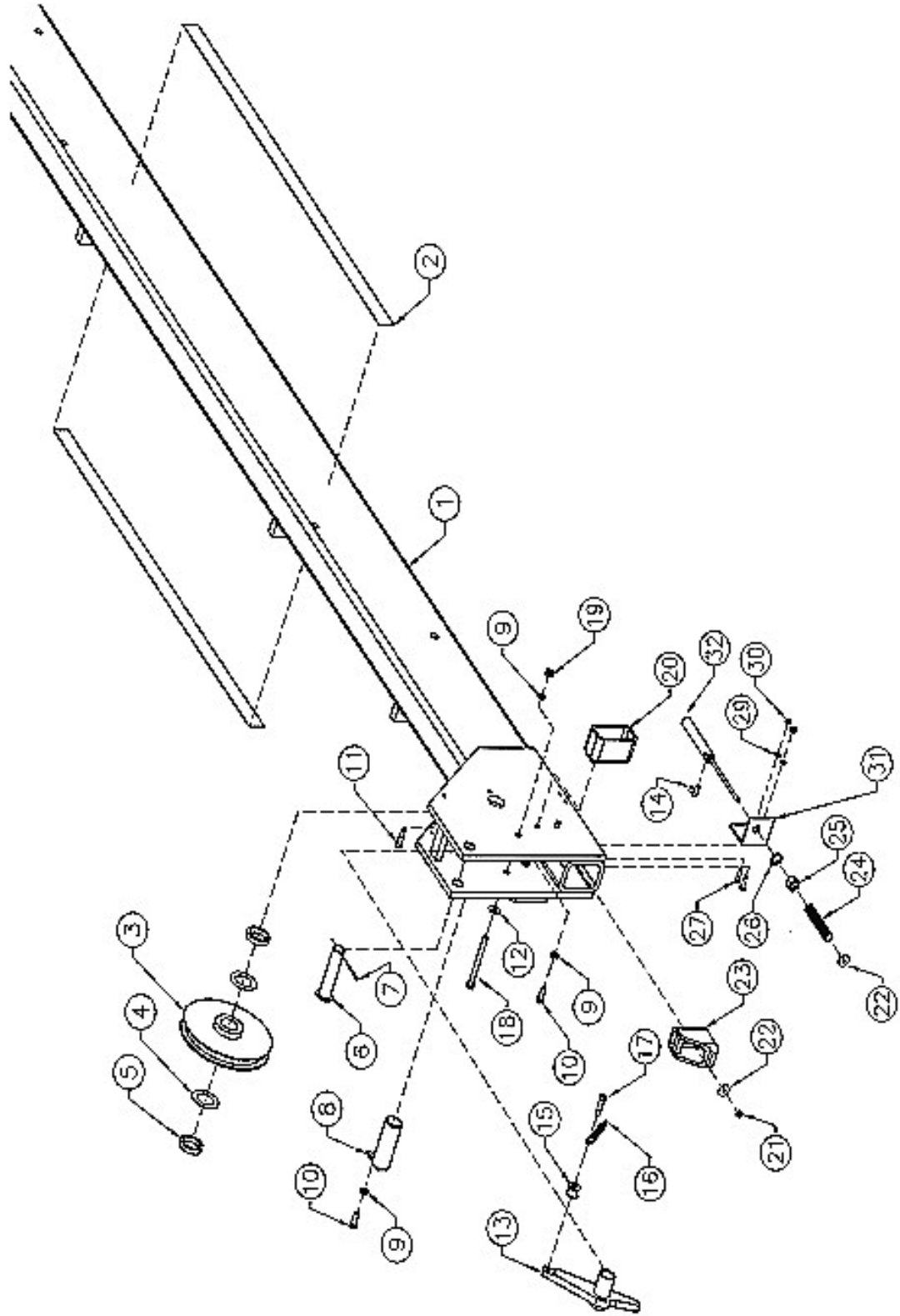

7.8 PARTS LIST- CROSSMEMBER ASSEMBLY

ITEM	QTY.	DESCRIPTION	PART #
1	1	FRONT CROSSMEMBER WELDMENT	4-0627
	1	REAR CROSSMEMBER WELDMENT	4-0626
2	2	"CAUTION" TAPE, 40" LONG	6-1125
3	2	SHEAVE ASSEMBLY	2-1377
4	4	NYLON THRUST WASHER	1-0757
5	4	SHEAVE SPACER, 3/8" LONG	1-0786
6	2	LOCK SAFETY PIN WELDMENT	1-1744
7	2	COTTER PIN, 1/8" x 2" LG	6-0115
8	2	CROSSMEMBER SHEAVE PIN WELDMENT	2-1356
9	12	LOCKWASHER, 3/8" I.D.	6-0058
10	10	HEX BOLT, 3/8"-16UNC x 1" LG	6-0668
11	2	SHOULDER BOLT, 3/8" x 5/8" LG	6-0069
12	2	FLAT WASHER, 3/8"	6-0625
13	2	LOCK SAFETY	2-1424
14	2	90 ELBOW, 1/8"NPT x 1/4" POLYTUBE	6-0709
15	2	CABLE ROLLER	1-0766
16	4	TENSION SPRING	1-0768
17	2	SHOULDER BOLT, 3/8" x 1 1/2" LG	6-0801
18	2	HEX BOLT, 3/8"-16UNC x 4 1/2" LG	6-1693
19	2	HEX NUT, 3/8"-16UNC	6-0034
20	4	SLIDER BLOCK WELDMENT	2-1376
21	2	HEX NYLON LOCKNUT, 1/4"-28UNF	6-1563
22	4	FENDER WASHER, 1/4" I.D.	6-0626
23	2	SAFETY SHOE WELDMENT	2-1378
24	2	COMPRESSION SPRING	1-0767
25	2	HEX NUT, 5/8"-18UNF	6-0662
26	2	INTERNAL TOOTH LOCKWASHER, 5/8"ID	6-0663
27	4	HEX BOLT, 1/4"-20UNC x 1" LG	6-0008
29	4	LOCKWASHER, 1/4" I.D.	6-0056
30	4	HEX NUT, 1/4"-20UNC	6-0032
31	2	AIR CYLINDER BRACKET	1-1712
32	2	AIR CYLINDER	6-0651

7.9 CYLINDER ASSEMBLY

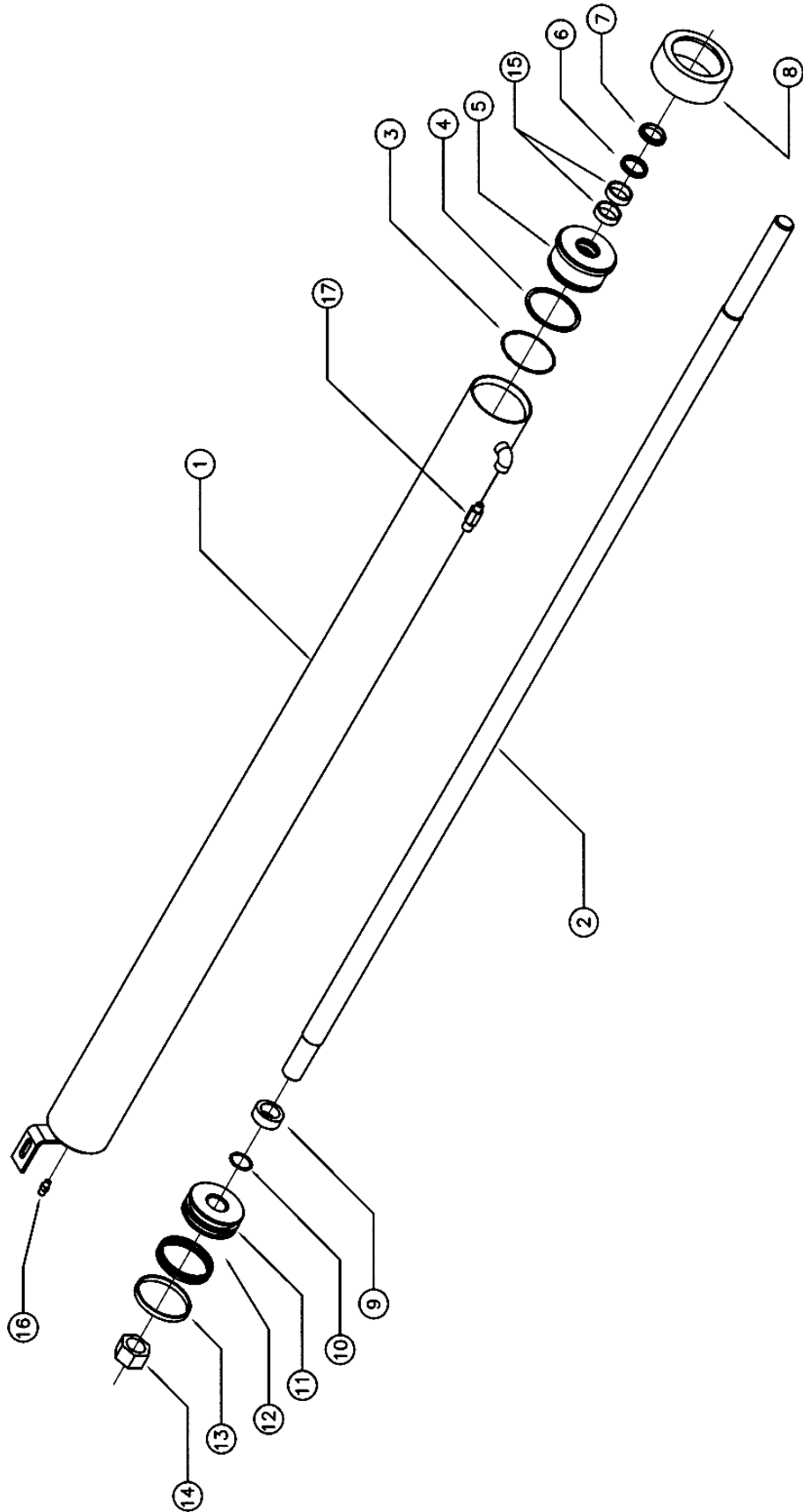

7.10 PARTS LIST - CYLINDER ASSEMBLY

ITEM	QTY.	DESCRIPTION	PART #
1	1	CYLINDER TUBE WELDMENT 4" BORE	2-1345
2	1	PISTON ROD - MACHINED	2-1340
3	1	ORING, 4"OD x 1/8"C/S	6-1633
4	1	BACKUP RING	6-1634
5	1	GLAND	3-0673
6	1	ROD SEAL, 1½"ID x 1 7/8"OD x 1/4"	6-1892
7	1	ROD WIPER, 1½"ID x 1 7/8"OD x 3/16"	6-0001
8	1	TUBE NUT	2-1343
9	1	KEEPER WASHER	1-1689
10	1	ORING, 1 3/8"ID x 1/8"C/S	6-1632
11	1	PISTON	2-1344
12	1	ROD SEAL, 4"OD x 3½"ID	6-1636
13	1	WEAR RING, 4"OD x 3/8"WIDE x 1/8"THK	6-1635
14	1	LOCKNUT, 1 3/8"-12UNF	6-1645
15	2	WEAR RING, 1 3/4"OD x ½"WIDE x 1/8"THK	6-1686
16	1	ADAPTOR, 1/8"NPT-M TO 1/4"JIC-M	6-0280
17	1	VELOCITY FUSE - 8GPM	6-1684

7.12 PARTS LIST- HYDRAULIC AND AIR KIT

ITEM	QTY.	DESCRIPTION	PART #
1	8	90° ELBOW, 1/8" NPT x 1/4" POLYTUBE	6-0709
2	4	AIR CYLINDER	6-0651
3	10FT	1/4" DIA. POLY TUBE	6-1396
4	3	ADAPTER, 3/8" POLY TUBE x 1/4" NPT	6-0710
5	2	TERMINAL BOLT, 3/4"	6-0713
6	2	PLUG, 1/4" NPT	6-0282
7	3	1/4" NPT STREET TEE	6-0014
8	1	1/4" NPT STREET ELBOW	6-0015
9	10FT	3/8" DIA. POLY TUBE	6-1400
10	1	FLOW CONTROL	6-1691
11	4FT	HOSE GUARD	6-0714
12	1	POWER PACK 230V/1 PH	6-1695
	1	POWER PACK 230V/3 PH	6-2615
13	1	HYD.HOSE ASS'Y, 3/8" JIC FEMALE, 16FT LONG	6-1692
14	3	CABLE TIE	6-0731
15	2	HEX NUT, #8-32	6-1095
16	1	"NOTICE" DECAL	6-0594
17	1	90° ELBOW, 1/4" NPT M x 3/8" NPT F	6-0796
18	3	ADAPTER, 1/4" POLY TUBE x 1/8" NPT	6-0708
19	1	3-WAY AIR VALVE	6-1775
20	1	AIR FILTER ASSEMBLY	6-0772
	1	AIR FILTER ELEMENT, (REPLACEMENT)	6-0180
21	1	AIR VALVE FITTING KIT	0-0405
22	1	VELOCITY FUSE 8GPM	6-1684
23	1	PLUG, 1/8" NPT	6-0182
24	2	MANIFOLD	1-1057
25	4	HEX HD.BOLT, 1/4"-20UNC X 2" LG	6-0177
26	4	HEX NUT, 1/4"-20UNC	6-0032
27	4	LOCKWASHER, 1/4" I.D.	6-0056
28	2	PHIL. HD. SCREW, #8-32 X 1" LG.	6-1094
29	1	"LIFT OPERATION" DECAL	6-0593
30	1	ADAPTER, 1/8" NPT M X 1/4" JIC M	6-0280
31	1	AIR VALVE PUSHBUTTON KIT	6-1777
32	1	RECOIL HOSE	6-0337
*		AIR VALVE & FILTER ASSEMBLY	2-1394

7.13 CABLE ROUTING

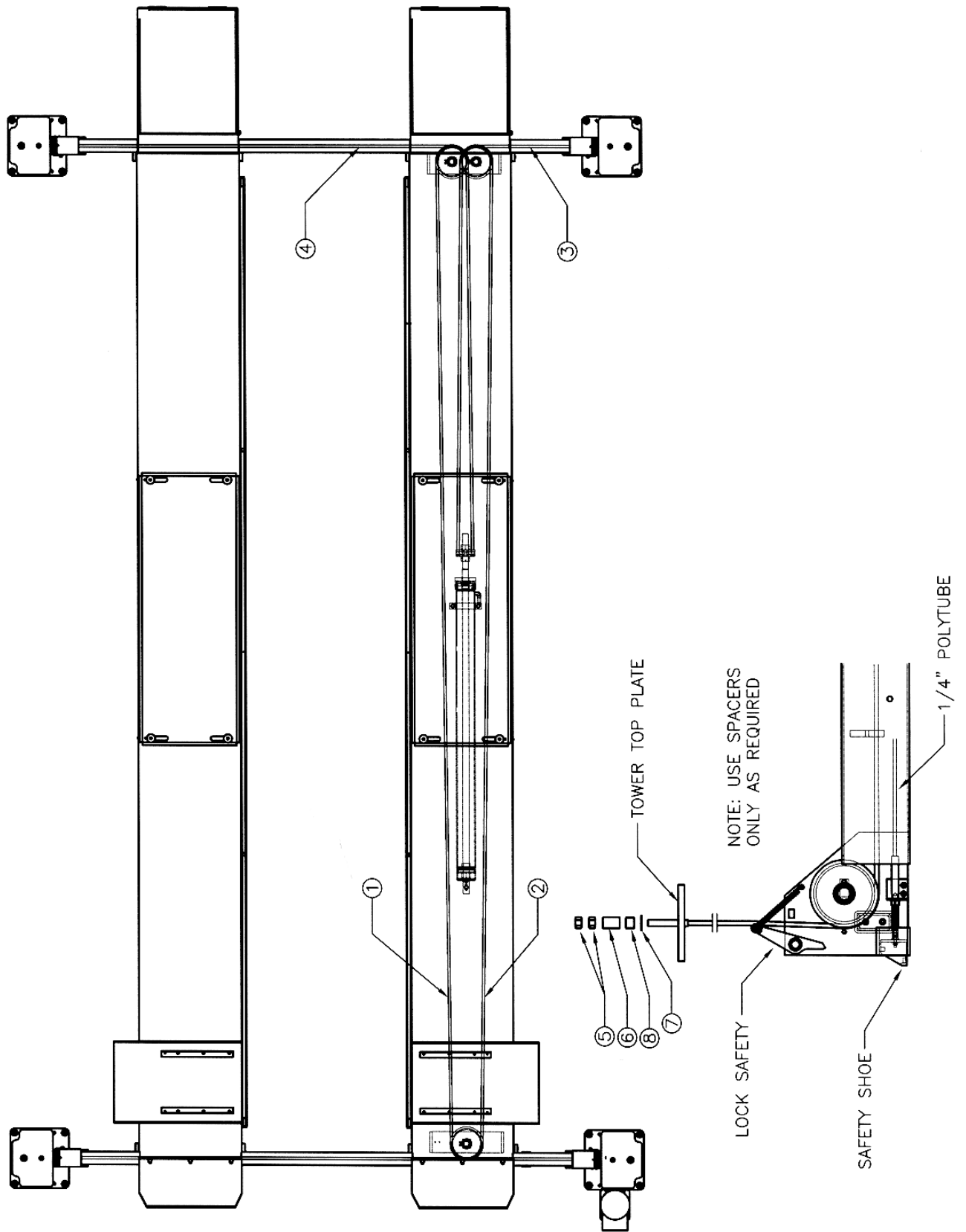

7.14 PARTS LIST - CABLE ROUTING

ITEM	QTY.	DESCRIPTION	PART #
1	1	CABLE ASSY. 407.5" - FRONT LEFT	2-1360
2	1	CABLE ASSY. 473.5" - FRONT RIGHT	2-1361
3	1	CABLE ASSY. 162" - REAR LEFT	2-1362
4	1	CABLE ASSY. 228" - REAR RIGHT	2-1363
5	8	HEX NUT, 7/8"-14UNF GR8	6-0724
6	4	CABLE SPACER, 2"LG	1-0800
7	4	FLAT WASHER, 7/8"ID	6-0725
8	4	CABLE SPACER, 1"LG	1-0801

7.15 POWER PACK ASSEMBLY

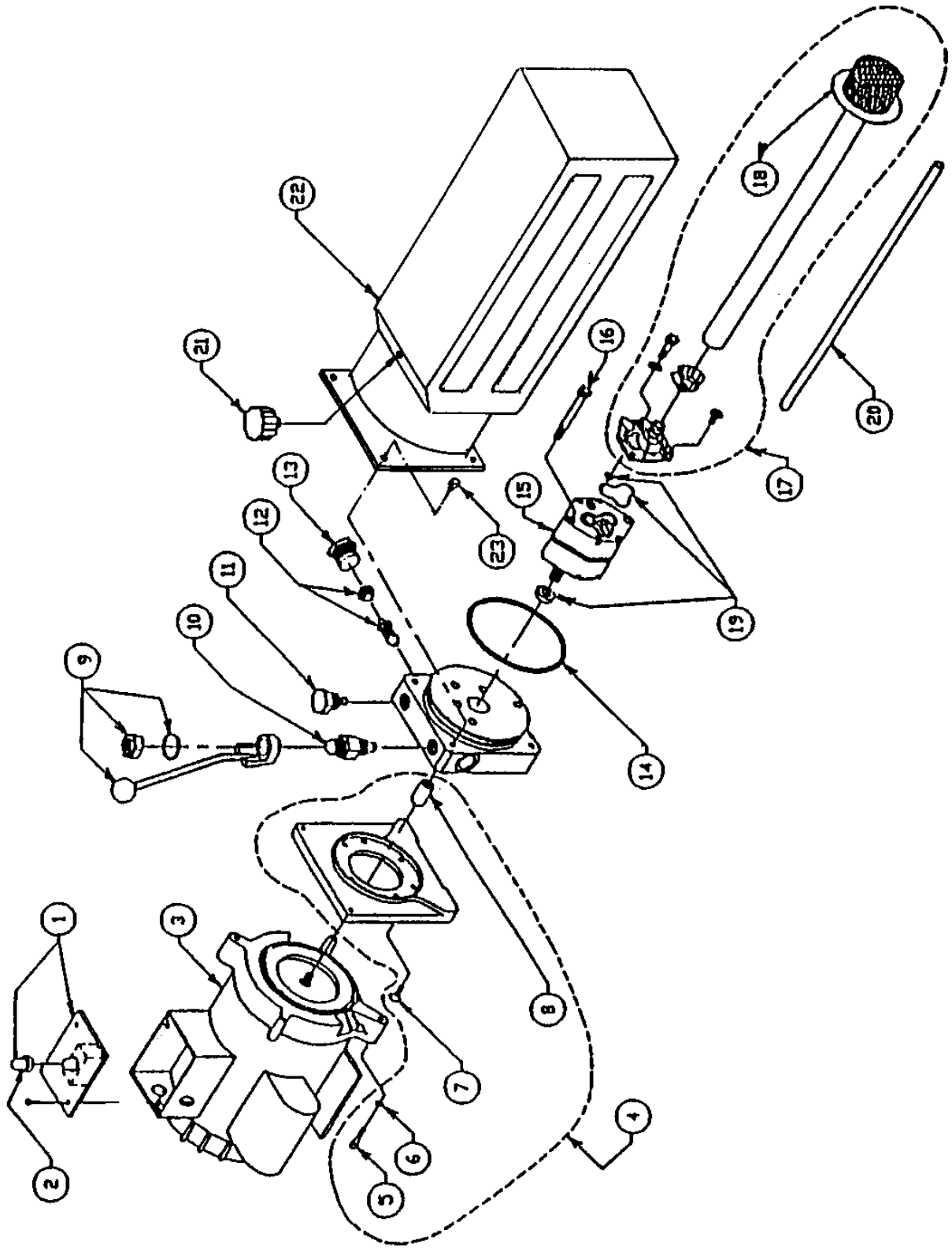

7.16 PARTS LIST - POWER PACK

ITEM	QTY.	DESCRIPTION	PART #
1	1	MICROSWITCH AND WIRING ASSEMBLY, 1PH	6-0881
	1	MICROSWITCH AND WIRING ASSEMBLY, 3PH	6-0918
2	1	MICROSWITCH BOOT	6-1084
3	1	MOTOR, 230V AC, 1 PHASE, 60 HERTZ 3HP	6-1959
	1	MOTOR, 230V AC, 3 PHASE, 60 HERTZ	6-1079
4	1	MOTOR ADAPTER KIT	0-0197
5	4	SOCKET HD.CAP SCW. 1/4"-20UNC X 1 5/8"LG.	6-1085
6	4	LOCK WASHER, 1/4" I.D.	6-0056
7	4	ALLEN FLAT HD.SCW. 1/4"-20UNC X 3/4"LG.	6-1086
8	1	COUPLING	6-0774
9	1	RELEASE BRACKET & HANDLE ASSEMBLY	6-0776
10	1	VALVE CARTRIDGE RELEASE	6-0880
11	1	VALVE CARTRIDGE CHECK	6-1087
12	1	FIXED RELIEF VALVE ASSEMBLY (RV 19)	6-1319
13	1	RELIEF VALVE CAP	6-1089
14	1	RESERVOIR "O" RING	6-0875
15	1	PUMP ASSEMBLY	6-1688
16	2	PUMP MOUNTING BOLT	6-1090
17	1	INLET PLUMBING KIT	0-0198
18	1	INLET HOSE / FILTER ASSEMBLY	6-0786
19	1	PUMP "O" RING KIT	0-0199
20	1	RETURN TUBE	6-0783
21	1	BREATHER FILLER CAP	6-1376
22	1	RESERVOIR	6-2828
23	4	RESERVOIR SCREW	6-1091

CAUTION

ALL SAFETY LADDERS USED ON 4-POST LIFTS ARE PRELOADED.

REMOVING THE BOLT HOLDING THE BOTTOM PORTION OF THE SAFETY LADDER WITHOUT PROPER PRECAUTIONS CAN RESULT IN INJURY.

PLEASE CONTACT CUSTOMER SERVICE FOR PROPER REMOVAL INSTRUCTIONS.

